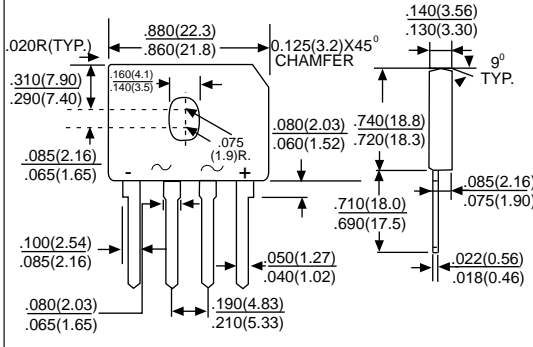

GBU4A/6A/8A SERIES

<p>SINGLE PHASE 4.0/6.0/8.0 AMPS. GLASS PASSIVATED BRIDGE RECTIFIERS</p>	<p>Voltage Range 50 to 1000 Volts Current 4.0/6.0/8.0 Amperes</p>
<p>Features</p> <ul style="list-style-type: none"> *Ideal for printed circuit board *Reliable low cost construction *Plastic material has Underwriters Laboratory Flammability Classification 94V-0 *Surge overload rating to 150 amperes peak *High temperature soldering guaranteed: 250°C/10 seconds/.375"(.9.5mm) lead lengths at 5 lbs..(2.3kg) tension <p>Mechanical Data</p> <ul style="list-style-type: none"> *Case: Molded plastic body *Terminals: Leads solderable per MIL-STD-750, Method 2026 *Weight: 0.3 ounce, 8.0 grams *Mounting torque: 5 in.lbs. Max. 	<p>GBU</p>  <p style="text-align: right;">Dimensions in inches and (millimeters)</p>

MAXIMUM RATINGS AND ELECTRICAL CHARACTERISTICS

Rating at 25°C ambient temperature unless otherwise specified.
Single phase, half wave, 60Hz, resistive or inductive load.
For capacitive load, derate current by 20%

Type Number		GBU 4005	GBU 401	GBU 402	GBU 404	GBU 406	GBU 408	GBU 410	UNITS	
		6005	601	602	604	606	608	610		
Maximum Repetitive Peak Reverse Voltage	VRRM	50	100	200	400	600	800	1000	V	
Maximum RMS Voltage	VRMS	35	70	140	280	420	560	700	V	
Maximum DC Blocking Voltage	VDC	50	100	200	400	600	800	1000	V	
Maximum Average Forward Rectified Current @Tc = 100°C	IF(AV)	4.0/6.0/8.0							A	
Peak Forward Surge Current, 8.3 ms Single Half Sine-wave Superimposed on Rated Load (JEDEC method)	IFSM	150/175/200							A	
Maximum Instantaneous Forward Voltage Drop Per Leg @4.0A/6.0A/8.0A	VF	1.0							V	
Maximun DC Reverse Current @ TA = 25°C at Rated DC Blocking Voltage @ TA = 125°C	IR	5.0 500							µA µA	
Typical Thermal Resistance (Note 1) (Note 2)	RJA RJC	20/7.0/21.0 4.0							°C/W	
Typical Junction Capacitance (Note 3)	CJ	100/211/211				45/94/94				pF
Operating Temperature Range	TJ	-55 to +150							°C	
Storage Temperature Range	TSTG	-55 to +150							°C	

NOTES:GBU4005 Thru GBU410: 1.Mounted on P.C.B. with 0.5 x 0.5" (12 x12mm) Copper Pads and 0.375"9.5mm) Lead Length.
2. Mounted on Al.Pate of 1.6 x1.6 x0.06"THK (4 x 4 x 0.15cm).
GBU4005 Thru GBU410: 1.Mounted on Al.Plate Heatsink of 2.6 x 1.4 x 0.06"THK (6.5 x 3.5 x 0.15cm).
2.Bolt on Heatsink with silicone Thermal Compound for Maximun Heat Transfer with #6 Screws.
GBU4005 Thru GBU410: 1.Units Mounted In Free Air No Heat Sink On PCB 0.5 x 0.5" (12 x 12mm) Copper Pads, 0.375" (9.5mm) Lead Length.
2.Units Case Mounted On 3.2 x 3.2 x 0.12" Thick (8.2x8.2x0.3cm) AL.Plate Heat Sink.
3.Measured at 1.0 MHz and Applied Reverse Voltage of 4.0 Volts.

RATING AND CHARACTERISTIC CURVES

GBU4A/6A/8A SERIES

FIG.1- MAXIMUM NON-REPETITIVE FORWARD SURGE CURRENT PER BRIDGE ELEMENT

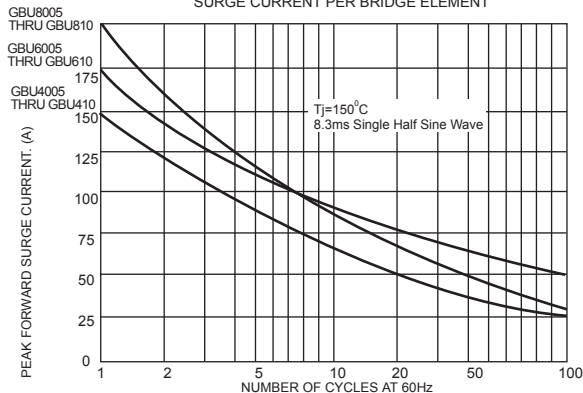

FIG.2-MAXIMUM FORWARD CURRENT DERATING CURVE

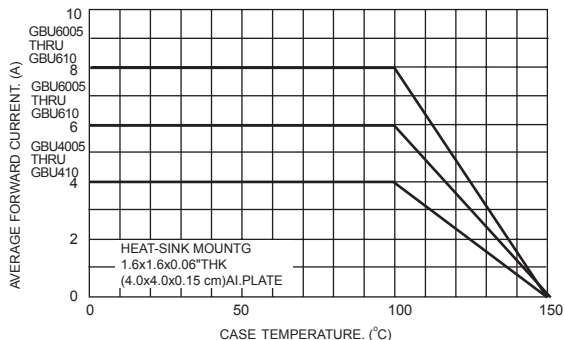

FIG.3 TYPICAL INSTANTANEOUS FORWARD CHARACTERISTICS PER BRIDGE ELEMENT

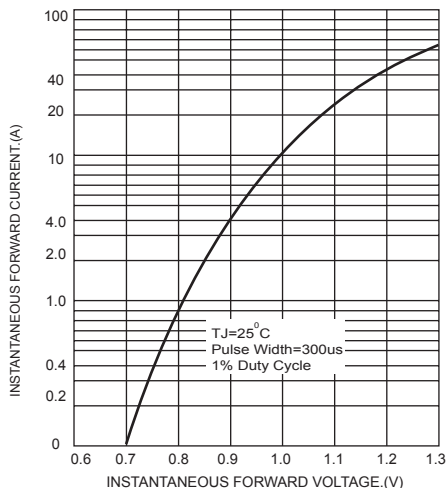

FIG.4-TYPICAL REVERSE CHARACTERISTICS PER BRIDGE ELEMENT(GBU6005 THRU GBU610)

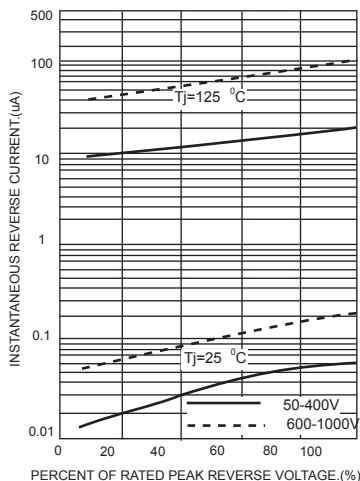

FIG.4-TYPICAL REVERSE CHARACTERISTICS PER BRIDGE ELEMENT(GBU4005 THRU GBU410)

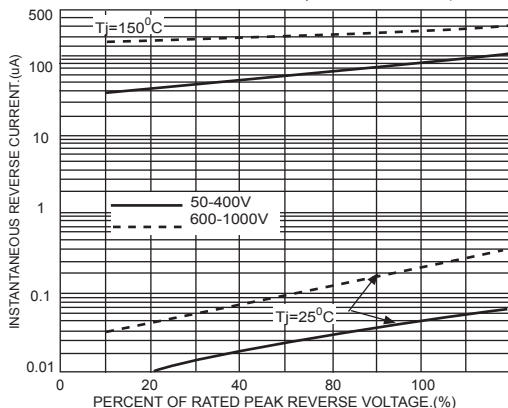

FIG.4-TYPICAL REVERSE CHARACTERISTICS PER BRIDGE ELEMENT(GBU6005 THRU GBU810)

